

## Cast Steel Globe Valve

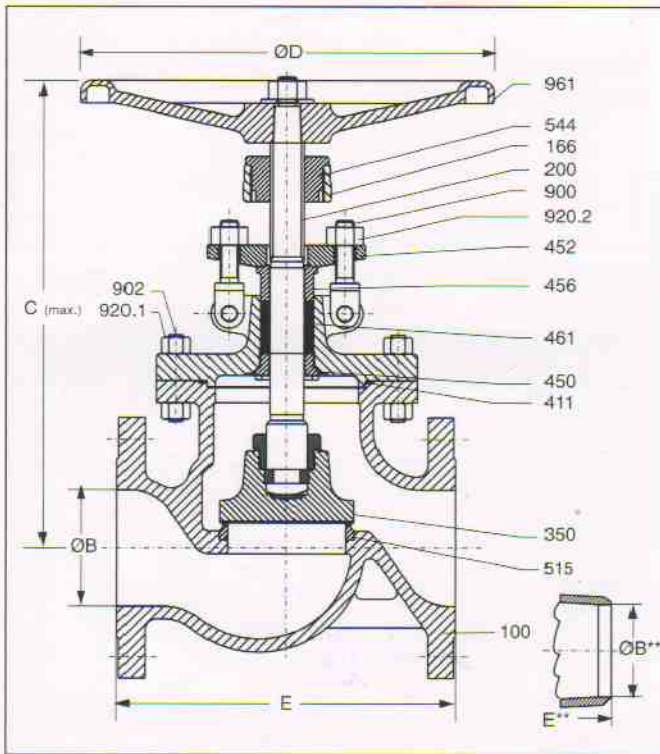

### Dimensions in mm

#### Class 150

	50	80	100	150	200	250
E	203.0	241.0	292.0	406.0	495.0	622.0
OB	51.0	76.0	102.0	152.0	203.0	254.0
C <sub>(max)</sub>	350.0	420.0	460.0	575.0	685.0	870.0
OD	203.0	254.0	356.0	356.0	457.0	508.0
E**	203.2	241.3	292.1	406.4	495.3	622.3
OB**	52.5	78.0	102.0	154.0	203.0	254.5

# Schedule 40 for class 150. Alternate schedule on request.

#### Class 300

	50	80	100	150	200	250
E	266.7	317.5	355.6	444.5	558.8	622.3
OB	51.0	76.0	102.0	152.0	203.0	254.0
C <sub>(max)</sub>	370.0	445.0	520.0	620.0	840.0	910.0
OD	203.0	254.0	356.0	457.0	457.0	508.0
E**	266.7	317.5	355.6	444.5	558.8	622.3
OB**	52.5	78.0	102.0	154.0	203.0	254.5

# Schedule 40 for class 300. Alternate schedule on request.

#### Class 600

	50	80	100	150	200	250
E	292.1	355.6	431.8	558.8	660.4	787.4
OB	51.0	76.0	102.0	152.0	200.0	248.0
C <sub>(max)</sub>	415.0	500.0	570.0	790.0	920.0	1140.0
OD	254.0	356.0	356.0	508.0	610.0	610.0
E**	292.1	355.6	431.8	558.8	660.4	787.4
OB**	49.2	73.5	97.0	146.5	193.5	243.0

# Schedule 80 for class 600. Alternate schedule on request.

### Design Specifications

General valve design	: BS 1873
Pressure, temperature rating	: ASME B 16.34
	Standard class
Flanged end design	: ASME B 16.5
Buttweld end design	: ASME B 16.25
End to end dimension /	
Face to face	: ASME B 16.10
Testing standard	: API 598

### Materials

Part No.	Description	Material			
100	Body	A 216-WCB	A 217-WC6	A 351-CF8	A 351-CF8M
166	Bonnet	A 216-WCB	A 217-WC6	A 351-CF8	A 351-CF8M
200	Stem	A 479-410-2	A 479-410-2	A 276-304	A 276-316
350	Disc	A 105+13% Cr	A 217-WC6+ST6	A 351-CF8	A 351-CF8M
		A 216-WCB+13%Cr			
411	Gasket	SS 316 + GRPH	SS 316 + GRPH	SS 316 + GRPH	SS 316 + GRPH
450	Back Seat	A 276-410 (H)	A 276-410 (H)	A 276-304	A 276-316
452	Gland Flange	A 105/ A 216-WCB	A 105 / A 216-WCB	A 351-CF8	A 351-CF8M
456	Gland Bush	A 276-410	A 276-410	A 276-304	A 276-316
461	Gland Packing	Graphite	Graphite	Graphite	Graphite
515	Seat Ring	A 105+ST6	A 182-F11 + ST6	A 351-CF8	A 351-CF8M
544	Stem Nut	A 439-D2	A 439-D2	A 439-D2	A 439-D2
900	Gland Bolt	A 307-B	A 307-B	A 182-F304	A 182-F304
902	Stud	A 193-B7	A 193-B16	A 193-B8	A 193-B8M
920.1	Hex. Nut	A 194-2H	A 194-4/7	A 194-8	A 194-8M
920.2	Hex. Nut		A 194-2H	A 194-8	A 194-8M
961	Handwheel	SG IRON / CS	SG IRON / CS	SG IRON / CS	SG IRON / CS