

Forbes Marshall Cast Strainer

Description

The Forbes Marshall Cast Strainer FMSTR51 / FMSTR52 is available in cast steel with stainless steel screen having 0.8 mm dia perforations as standard.

Size and Pipe Connections

DN 15, 20, 25, 40 and 50
Screwed BSPT, NPT and socket weld ends.
Available with IBR certificate.

Limiting Conditions

Max working Pressure(Kg/cm²)

Size DN	Screwed	Socket Weld
15	55.0	55.0
20	50.0	50.0
25	55.0	55.0
40	41.5	55.0
50	41.5	55.0

Max working temperature : 425°C
Cold hydraulic test pressure : Double the working pressure

Operating Range

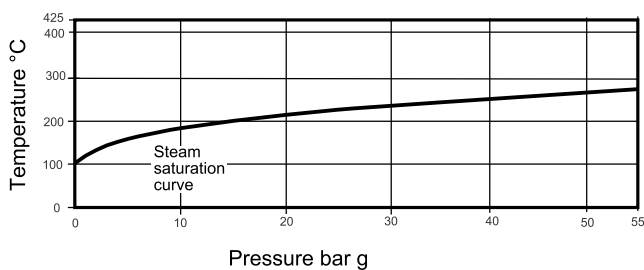

Dimensions: (approx.) in mm

Size DN	A	B	C	D	Weight
15	73	60	100	37	2 kg
20	88	65	110	40	2 kg
25	105	80	135	50	3 kg
40	162	125	195	74	7 kg
50	188	145	235	87	9 kg

Note : Blowdown or drain cock connections .The cap can be drilled to the following sizes to enable a blowdown or drain to be fitted.

Strainer size	Blowdown cock	Drain cock
15	3/8 "	3/8 "
20	1/2 "	1/2 "
25	1/2 "	1/2 "
40	3/4 "	3/4 "
50	3/4 "	3/4 "

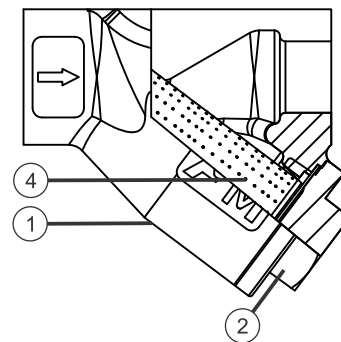
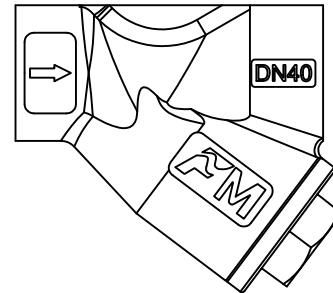

Materials

No	Part	Material	Standard
1	Body	Cast steel	ASTM A216-WCB
2	Cap	Cast steel	ASTM A216-WCB
3	Gasket	Reinforced exfoliated graphite	
4	Screen	Stainless Steel	ASTM A240 SS 304

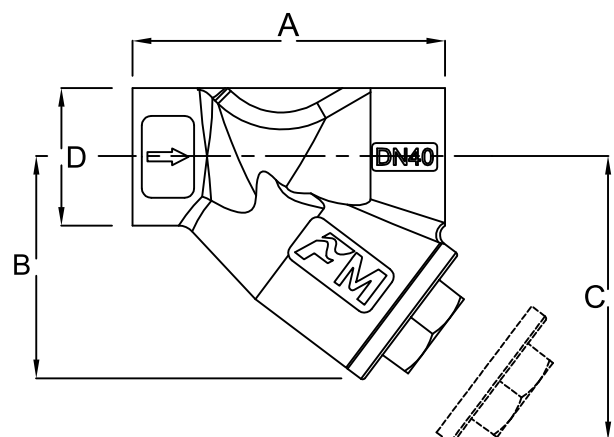

Installation

The strainer should be installed in the direction of flow, as indicated on the body. On applications involving steam or gases the pocket should be in the horizontal plane. On liquid systems the pocket should point downwards. Suitable isolation valves must be installed to allow for safe maintenance and trap replacement.

Maintenance note

Maintenance can be completed with the strainer in the pipeline.

How to Order

Example : 1 no. DN40 Forbes Marshall Cast Strainer FMSTR51 / FMSTR52, screwed BSPT, IBR

Recommended Tightening Torques

Size (DN)	Torque (Nm) for cap
15	50-55
20	60-66
25	100-110
40	230-250
50	330-360

Spare Parts

The spare parts available are shown in heavy outline in the figure below. Parts drawn in broken line are not supported as spares.

Available Spares

Strainer screen and gasket A+B

How to Order Spares

Always order spares by using the description given in the column headed Available Spares and stating the size and type of strainer and perforation or mesh required .

Example: 1No. strainer screen, stainless steel 304, 0.8mm perforation and gasket for DN40 Forbes Marshall Cast Strainer, FMSTR51 / FMSTR52.

Screen Details

Fitted as standard with a S.S 304 screen having perforation of 0.8mm Dia and other perforations are available to special order.

