

Forbes Marshall Pilot Operated Pressure Reducing Valve

Description

The Forbes Marshall Pilot Operated Pressure Reducing Valve, FMPRV41 is a SG iron pilot operated pressure reducing valve suitable for steam or compressed air.

Sizes and End Connections

DN 15, 20, 25, 40 and 50

Screwed: BSPT / NPT for DN 15, 20, 25

Flanged: BS 10 table "F/H" for DN 40 and 50

DN15 FMPRV41 LC versions available

Limiting Conditions

PMO-Maximum allowable pressure	17 bar g
TMO-Maximum allowable temperature	232°C
Cold hydraulic test pressure	34 bar g
Spring range	0.3 to 17 bar g

Pressure Sensing Pipe

The FMPRV41 controls the pressure by sensing the downstream pressure through a pressure sending pipe taken to the union (item L) or through the internal sensing pipe (item M). Fitting of the external pressure sensing pipe is described in the user manual supplied with the valve.

Note: Capacity is reduced and there is a possibility of hunting if an external pressure sensing pipe is not fitted.

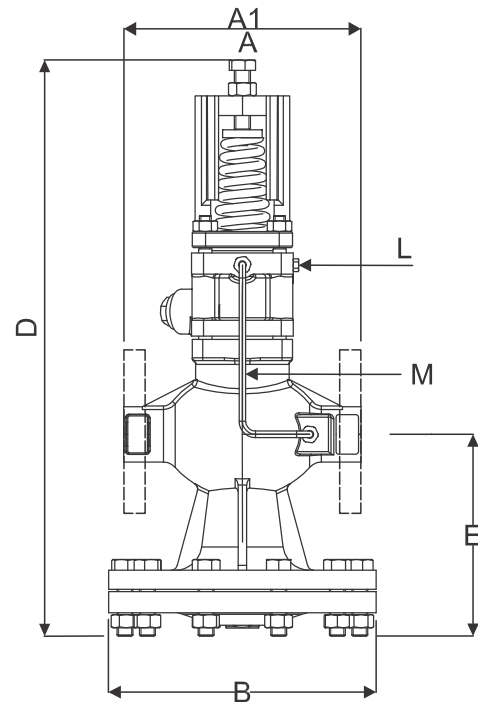

FMPRV41 STEAM

Dimensions (approx.) in mm

FMPRV41 (Steam)

Size	Screwed A	Flanged A1	B	D	E
DN15	160	181	410	130
DN15 LC	160	181	410	130
DN20	160	181	410	130
DN25	180	203	430	144
DN40	212	251	450	149
DN50	232	251	480	174

FMPRV41 (Air)

Size	Screwed A	Flanged A1	B	D	E
DN15	160	181	360	130
DN15 LC	160	181	360	130
DN20	160	181	360	130
DN25	180	203	383	144
DN40	212	251	415	149
DN50	232	251	415	174

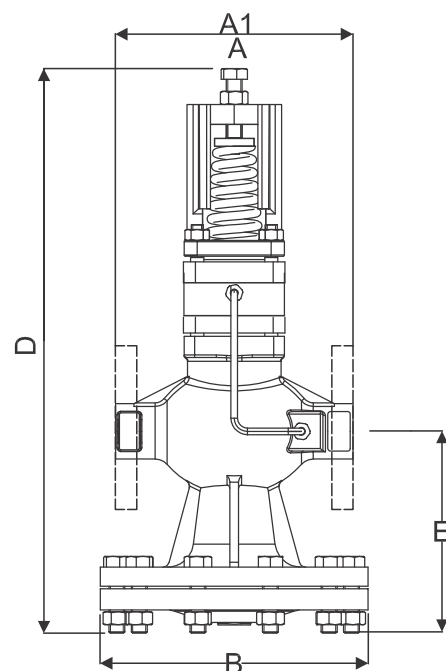

FMPRV41 AIR

Materials

No	Part	Material	Standard
1	Adjustments screw	Carbon Steel	IS1367Gr14
2	Adjustment lock nut	SS Type 304	
3	Spring housing	SG iron	EN-JS1025 DIN EN 1563
4	Top spring pad	C-20	IS2062
5	Pressure adjustment Spring	SS Type 302	IS4454 Part IV Gr.1
6	Bottom spring pad	SS Type 304	ASTM A276
7	Spring housing Securing nut Securing studs	Carbon Steel Carbon Steel DN 15-32 DN 40, 50	HT IS 1367 HT IS 1367 M10x95mm M12x95mm
8	Pilot diaphragms	SS Type 304	ASTM A240
9	Pilot valve chamber	SG iron	EN-JS1025 DIN EN1563
10	Pilot valve plunger	SS Type 304	
11	Pilot valve seat with integral seal	SS +PTFE	BS 970 431 S29
12	Pilot valve ball	SS	AISI 420
13	Pilot valve Spring	SS	BS 2057 302 S26
14	Pilot Valve clip	SS	ASTM A240 Type 301
15	Pilot filter cap gasket	SS	BS 1449-304-S16
16	Pilot filter cap	SS	ASTM A743Gr. CA 40
17	Pilot filter element	Bronze	
18	Internal strainer	SS	ASTM A240 Type 304
19	Body gasket	SS forced exfoliated graphite	
20	Main valve return spring	Stainless Steel	BS 2056 302 S26
21	Main valve	Stainless Steel	ASTM A276 Type 420
22	Main valve seat	Stainless Steel	ASTM A276 Type 420
23	Balance pipe assembly	Stainless Steel	ASTM A213 Type 304
24	Main Valve body	SG iron	EN JS1025 DIN EN 1563
25	Lower diaphragm chamber	SG iron	EN-JS1025 DIN EN 163
26	Lower diaphragm chamber Securing nuts Securing Bolts	Carbon steel Carbon steel DN 15 - 25 DN 40, 50	S1367 S 1367 M12x50mm M12x50mm
27	Main diaphragm pad	SS Type 304	ASTM A240
28	Lower diaphragm pad	SS Type 304	ASTM A276
29	Pushrod	SS Type 431	
30	Lock nut	SS Type 316	
31	Control pipe assembly	SS Type 304	ASTM A213
32	Name plate	SS	

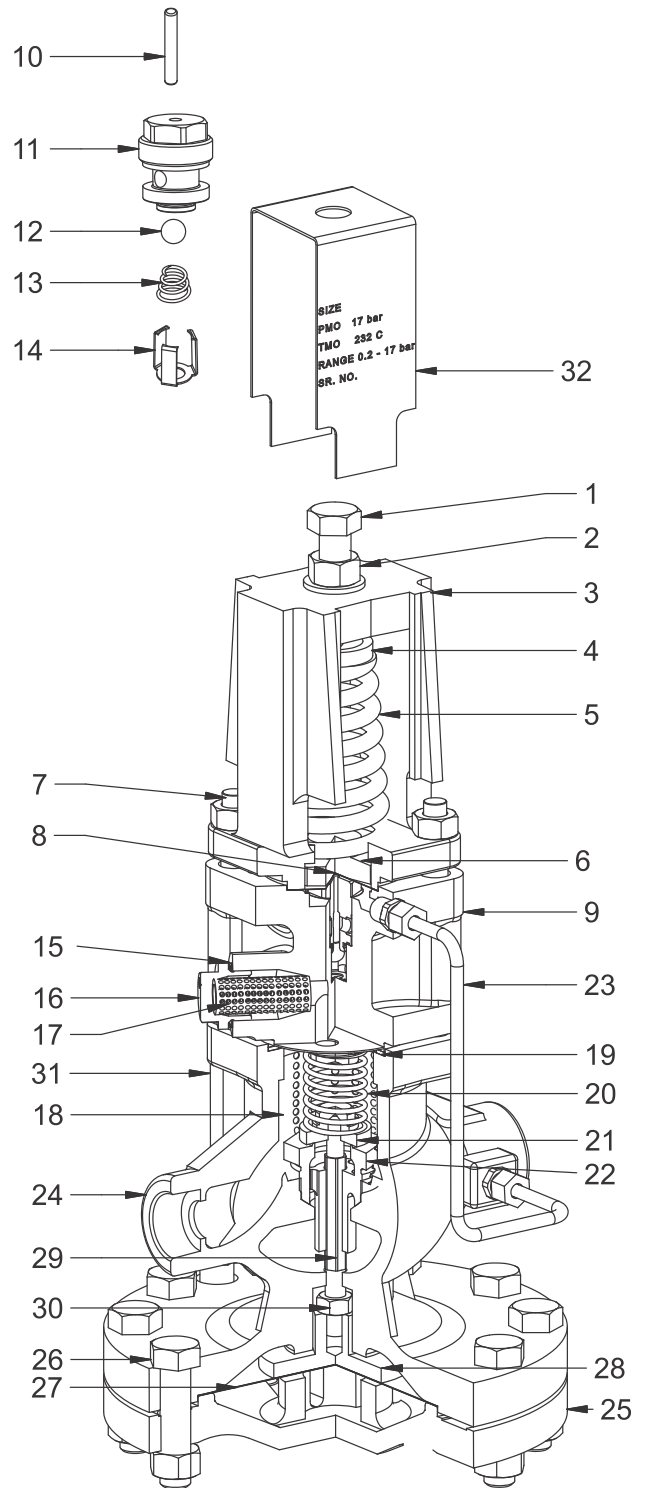

FMPRV41 STEAM

Note : Item 10,11,12,13 and 14 are shown on the exploded view, as they are hidden by the pilot filter on the main illustration.

Steam Capacity Chart

Note

The capacities quoted below are based on valves fitted with an external pressure sensing pipe. Reliance on the internal pressure sensing pipe will mean that capacities may be reduced. In the case of low downstream pressure this reduction could be up to 30% of the valve capacity.

How to Use the Chart

Saturated Steam

A valve is required to pass 600kg/h reducing from 6 bar g to 4 bar g. Find the point at which the curved 6 bar g upstream

pressure line crosses the horizontal 4 bar g downstream pressure line. A perpendicular dropped from this point gives the capacities of all FMPRV41 sizes under these conditions.

Superheated steam

Because of the higher specific volume of superheated steam a correction factor must be applied to the figure obtained from the chart above. For 55°C of superheat the factor is 0.95 and for 100°C of superheat the factor is 0.9.

Using the example given for saturated steam, the DN40 valve would pass $1150 \times 0.95 = 1092 \text{ kg/hr}$, if the steam had 55°C superheat. It is still big enough to pass the required load of 600kg/hr.

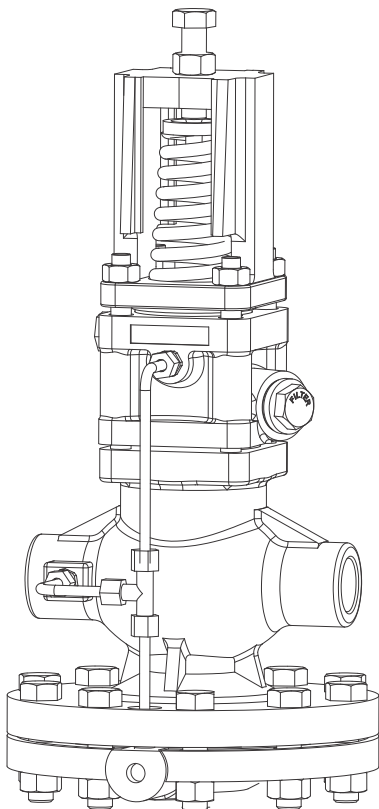
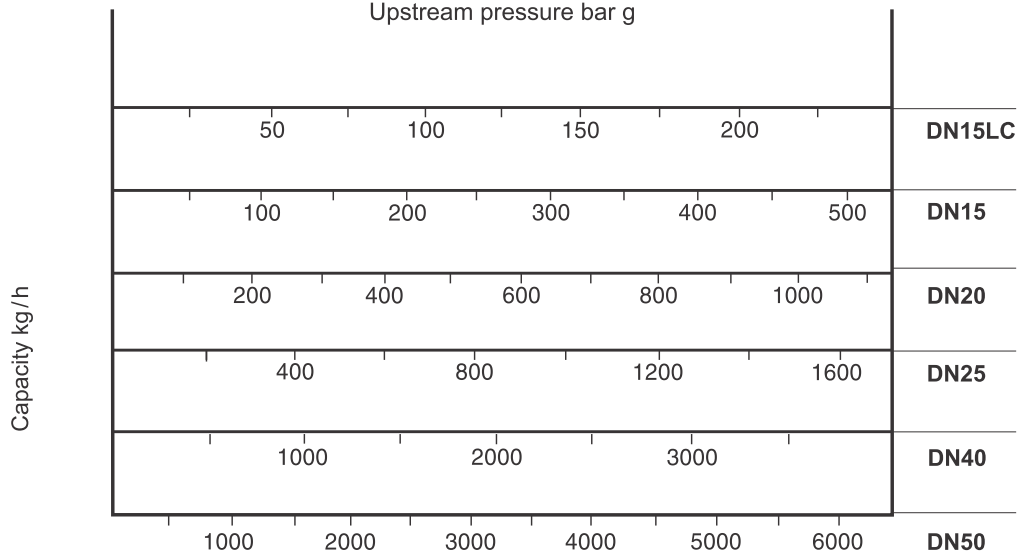
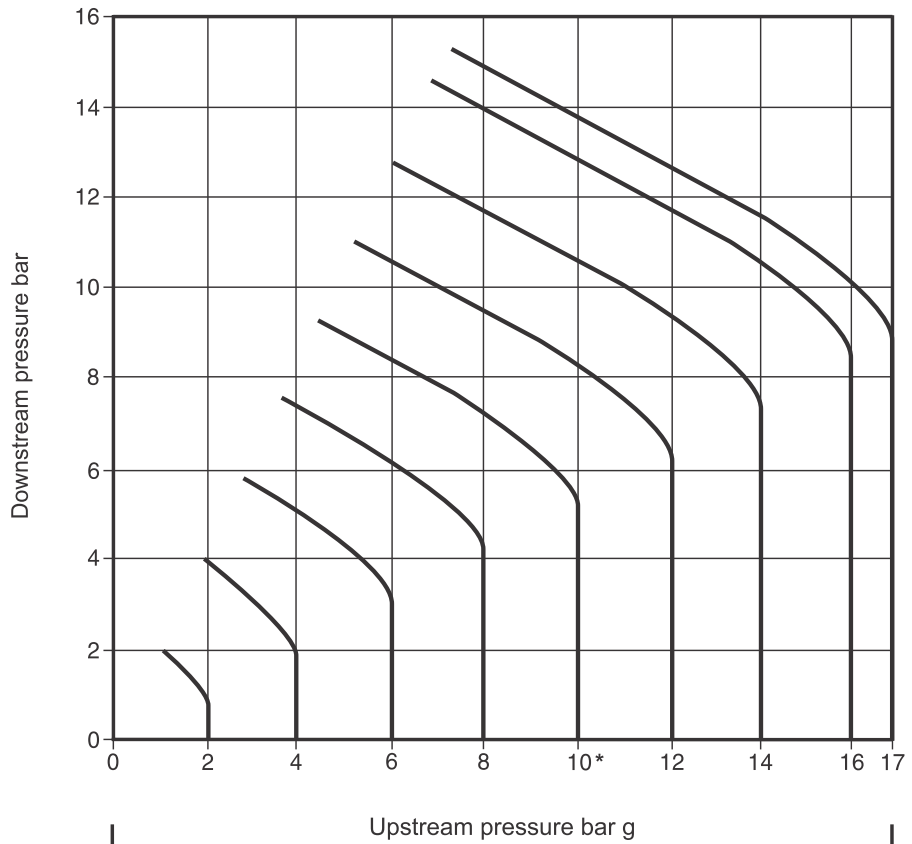

How to Use the Chart

Capacities are given in cubic decimeters of free air per second (dm³/s). The use of the capacity chart can be best explained by an example.

Required, a valve to pass 100dm³/s of free air reducing from 12 bar g to 8 bar g.

Find the point at which the curved 12 bar g upstream pressure line crosses the horizontal 8 bar g downstream pressure line. A perpendicular dropped from this point shows that, a DN15 valve will pass approximately 120 dm³/s under these conditions and is the correct valve size to choose.

KV Values

The Kv values are full capacities and should be used for safety valve sizing purpose only.

SIZE	DN15	DN20	DN25	DN40	DN50
KV	2.8	5.5	8.1	17	28

For conversion Cv (UK)=Kv x 0.963
Cv (US)=Kv x 1.156

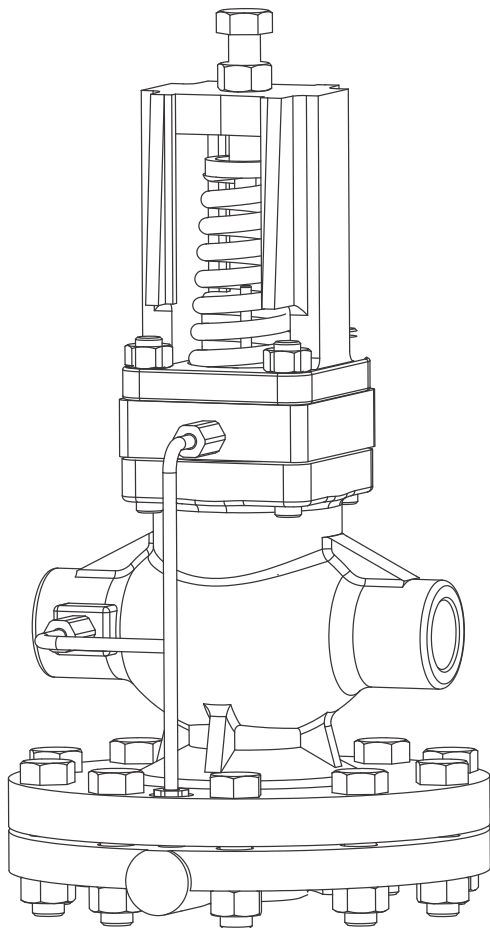

Compressed Air Capacity Chart

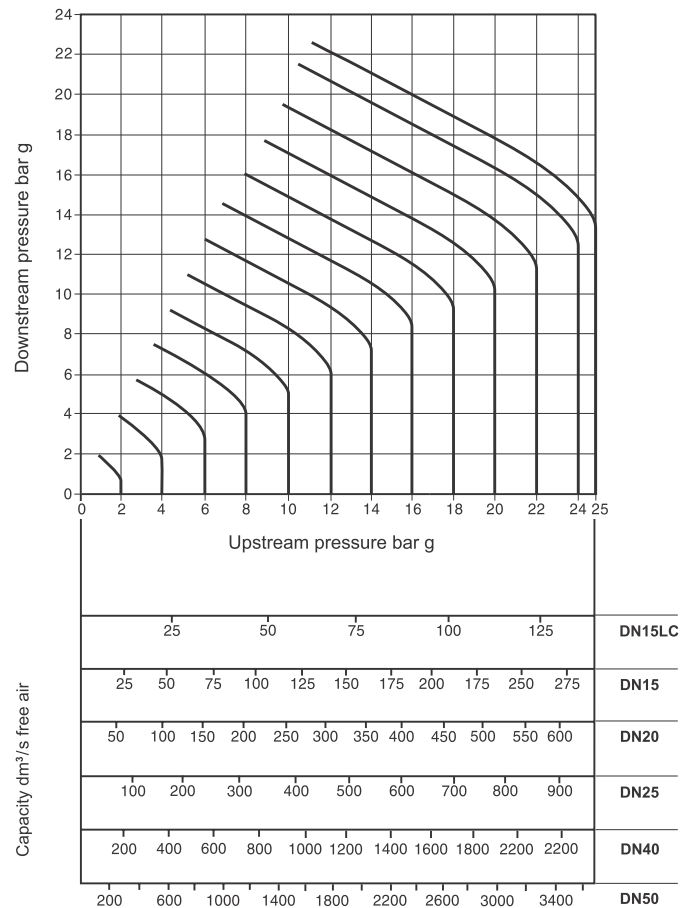

How to Order

1 no. Forbes Marshall Pilot Operated Pressure Reducing Valve, DN 40 FMPRV41 having a 0.2-17 bar g spring and flanged BS10 table "F/H" connections.

Installation note

The pilot operated pressure reducing valve should be installed in a horizontal pipeline, protected by a strainer and a separator, with the direction of flow as indicated by the arrow on the valve body.

Safety Information, Installation and Maintenance

For full details see the user manual supplied with the product.

Spare Parts

For spares refer user manual.